



(19) **United States**

(12) **Patent Application Publication**
Kuo et al.

(10) **Pub. No.: US 2013/0049640 A1**
(43) **Pub. Date: Feb. 28, 2013**

(54) **MIRROR ELECTROLUMINESCENT DISPLAY PANEL**

(52) **U.S. Cl. 315/312**

(76) Inventors: **Tzu-Yin Kuo, Hsin-Chu (TW); Hsing-Hung Hsieh, Hsin-Chu (TW)**

(57) **ABSTRACT**

(21) Appl. No.: **13/481,960**

A mirror electroluminescent display panel includes an array substrate, a plurality of driving devices, a plurality of electroluminescent devices, and a cover substrate. The driving devices and the electroluminescent devices are disposed on the array substrate. Each electroluminescent device includes a first electrode electrically connected to the corresponding driving device, a light-emitting layer disposed on the first electrode, and a second electrode disposed on the light-emitting layer. The cover substrate and the array substrate are disposed oppositely. The cover substrate has a plurality of transmission regions, and a reflection region disposed between adjacent transmission regions, and each of the transmission regions is corresponding to each of the light-emitting layers, respectively.

(22) Filed: **May 29, 2012**

(30) **Foreign Application Priority Data**

Aug. 26, 2011 (TW) 100130702

Publication Classification

(51) **Int. Cl. H05B 33/12 (2006.01)**

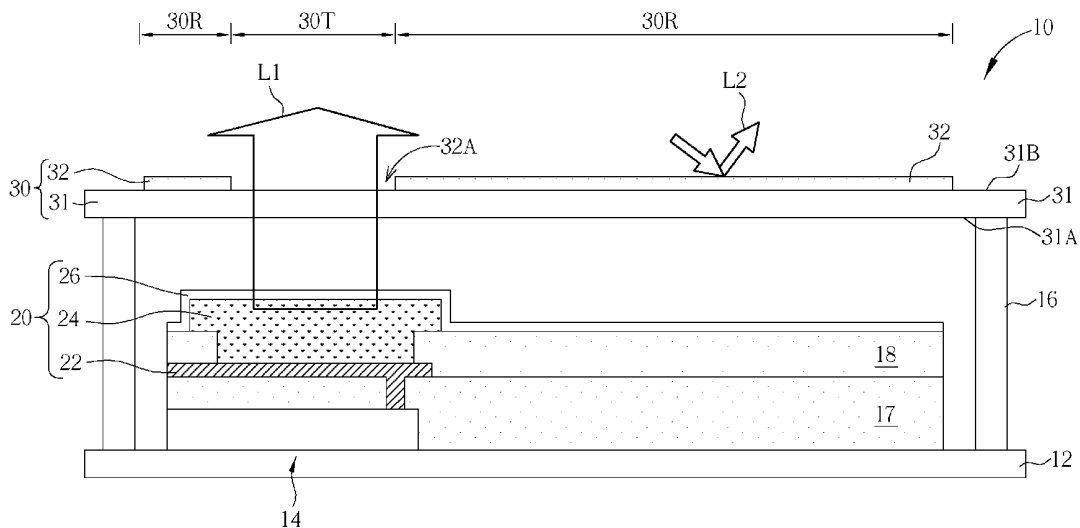

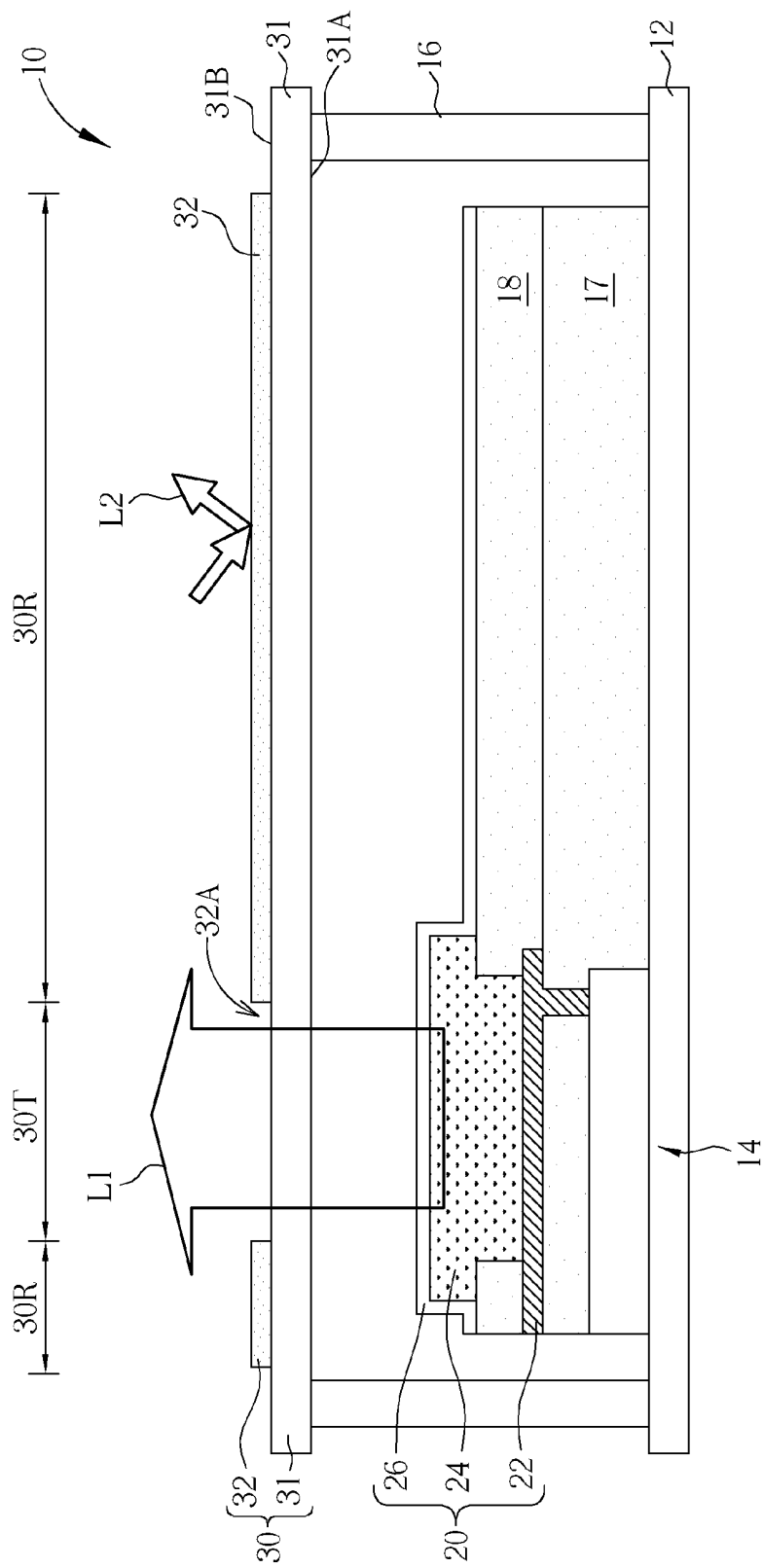

FIG. 1

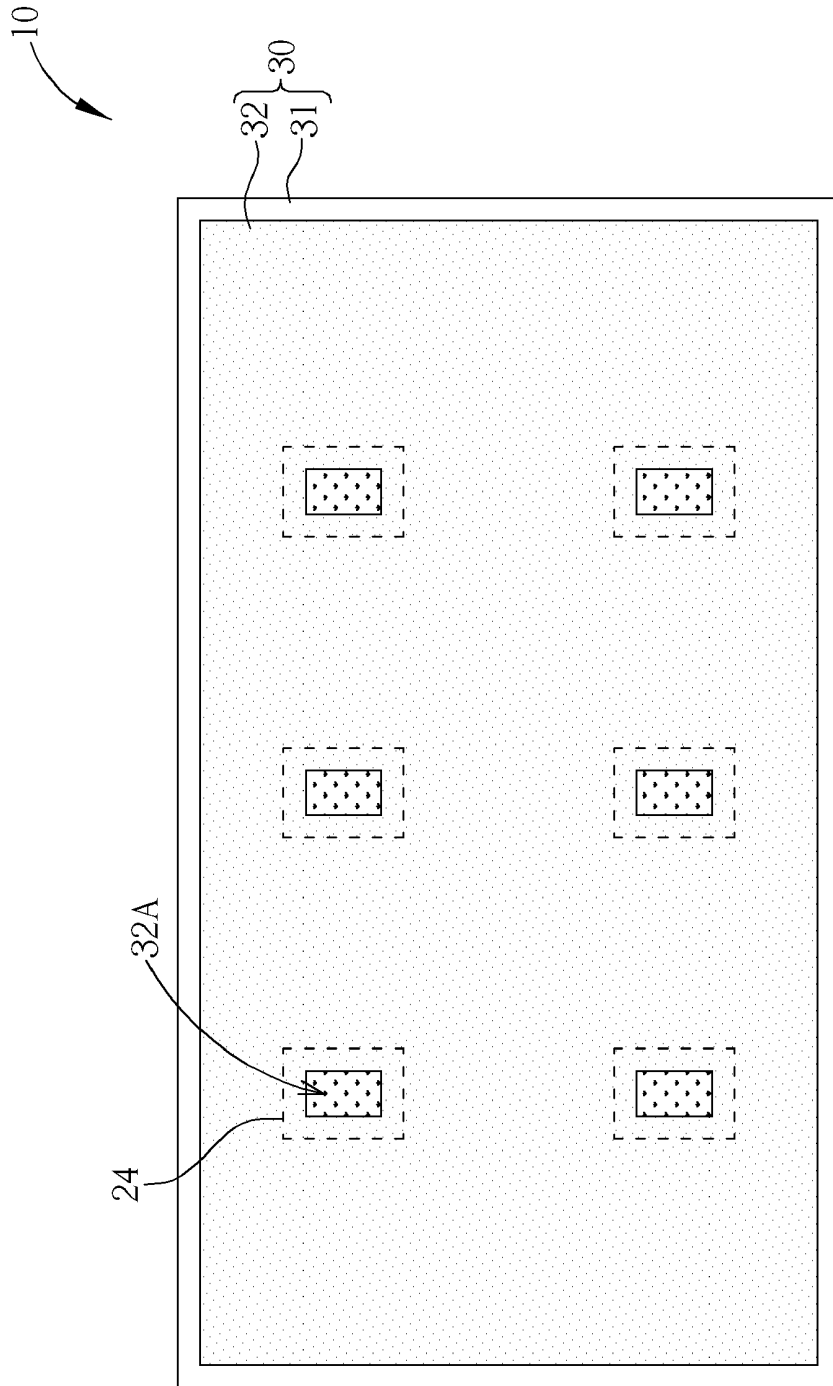

FIG. 2

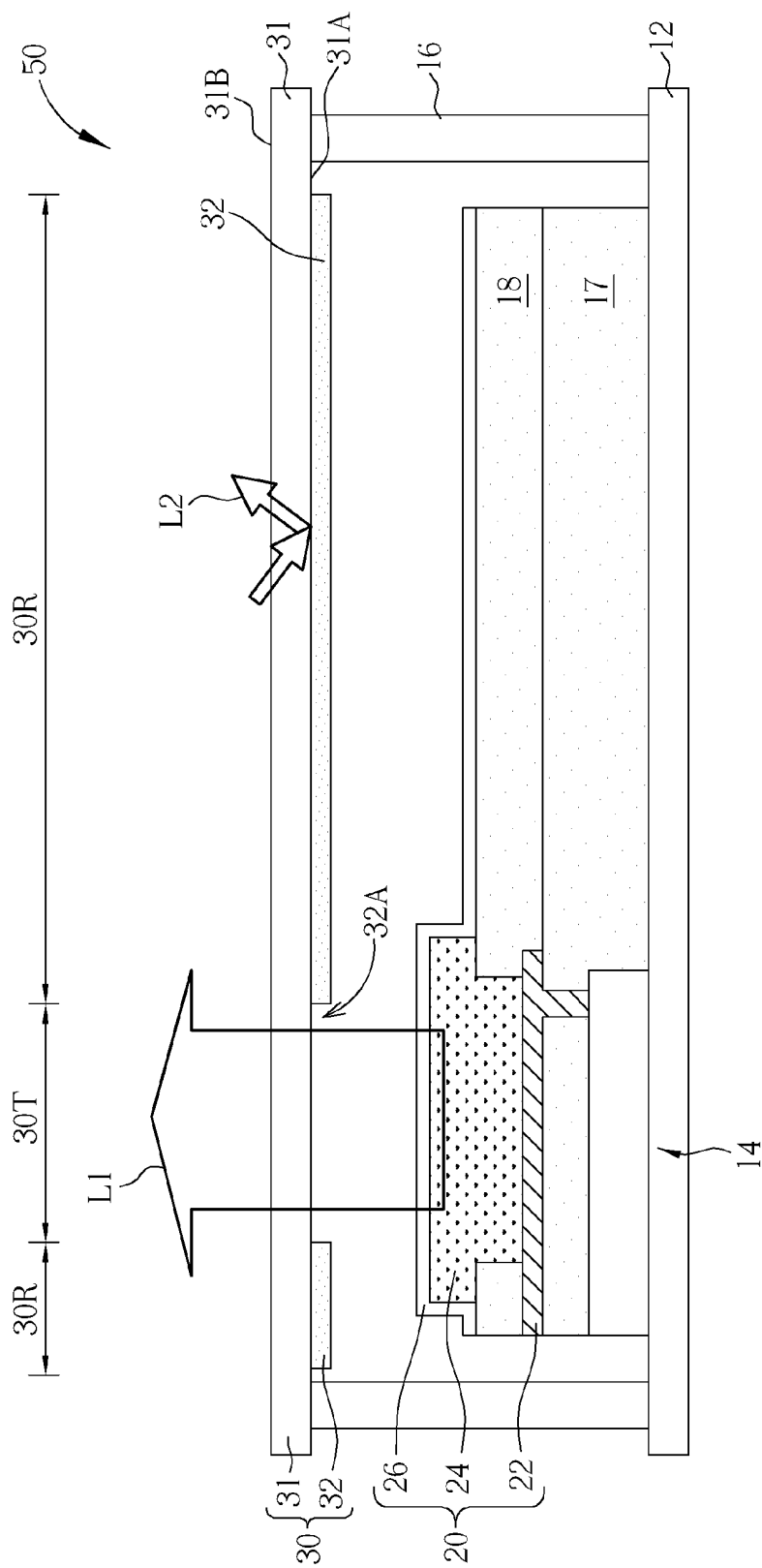

FIG. 3

MIRROR ELECTROLUMINESCENT DISPLAY PANEL

BACKGROUND OF THE INVENTION

[0001] 1. Field of the Invention

[0002] The present invention relates to a mirror electroluminescent display panel, and more particularly, to a mirror electroluminescent display panel with high brightness and low color aberration.

[0003] 2. Description of the Prior Art

[0004] In some certain applications, the display panel is provided with mirror effect. The mirror effect of a conventional display panel is implemented by bonding a reflective film to the entire display surface of the display panel. The reflective film is able to reflect ambient light, which makes the display panel look like a mirror in appearance, while the light emitted by the display panel can penetrate through the reflective film so the user can see the images. Despite a portion of light emitted by the display panel would pass through the reflective film, another portion of light emitted by the display panel would be absorbed or reflected by the reflective film, which causes light loss and therefore reduces the brightness of images. In addition, the transmission rate of the reflective film with respect to light of different colors is different, and that generates color aberration (color shift) in displaying. Therefore, the display quality of conventional mirror display panel needs to be improved.

SUMMARY OF THE INVENTION

[0005] It is therefore one of the objectives of the present invention to provide a mirror electroluminescent display panel to increase brightness and diminish color aberration of display images.

[0006] According to a preferred embodiment of the present invention, a mirror electroluminescent display panel is provided. The mirror electroluminescent display panel includes an array substrate, a plurality of driving devices, a plurality of electroluminescent devices, and a cover substrate. The driving devices and the electroluminescent devices are disposed on the array substrate. Each electroluminescent device includes a first electrode electrically connected to the corresponding driving device, a light-emitting layer disposed on the first electrode, and a second electrode disposed on the light-emitting layer. The cover substrate and the array substrate are disposed oppositely. The cover substrate has a plurality of transmission regions, and a reflection region disposed between a region between adjacent transmission regions. Each of the transmission regions is corresponding to each of the light-emitting layers, respectively.

[0007] The cover substrate of the mirror electroluminescent display panel of the present invention has the transmission regions corresponding to the light-emitting layers, and the transmission regions allow light emitted by the light-emitting layers passing through without loss. Consequently, the mirror electroluminescent display panel of the present invention can display images with high brightness and without color aberration. The reflection region of the cover substrate can reflect the ambient light to provide mirror effect.

[0008] These and other objectives of the present invention will no doubt become obvious to those of ordinary skill in the art after reading the following detailed description of the preferred embodiment that is illustrated in the various figures and drawings.

BRIEF DESCRIPTION OF THE DRAWINGS

[0009] FIG. 1 is a cross-sectional view of a mirror electroluminescent display panel according to a first preferred embodiment of the present invention.

[0010] FIG. 2 is a top view of a mirror electroluminescent display panel according to a first preferred embodiment of the present invention.

[0011] FIG. 3 is a cross-sectional view of a mirror electroluminescent display panel according to a second preferred embodiment of the present invention.

[0012] FIG. 4 is a cross-sectional view of a mirror electroluminescent display panel according to a third preferred embodiment of the present invention.

[0013] FIG. 5 is a cross-sectional view of a mirror electroluminescent display panel according to a fourth preferred embodiment of the present invention.

DETAILED DESCRIPTION

[0014] To provide a better understanding of the present invention to the skilled users in the technology of the present invention, preferred embodiments will be detailed as follows. The preferred embodiments of the present invention are illustrated in the accompanying drawings with numbered elements to elaborate the contents and effects to be achieved.

[0015] Please refer to FIG. 1 and FIG. 2. FIG. 1 is a cross-sectional view of a mirror electroluminescent display panel according to a first preferred embodiment of the present invention, and FIG. 2 is a top view of a mirror electroluminescent display panel according to a first preferred embodiment of the present invention. It is appreciated that some components of the electroluminescent display panel are not shown in FIG. 2. As shown in FIG. 1 and FIG. 2, the mirror electroluminescent display panel 10 includes an array substrate 12, a plurality of driving devices 14, a plurality of electroluminescent devices 20, and a cover substrate 30. The driving devices 14 are disposed on the array substrate 12, and the driving devices 14 may be, for instance, thin film transistor (TFT) devices, but not limited thereto. The electroluminescent devices 20 are disposed on the array substrate 12, and the electroluminescent device 20 may be, for instance, organic light-emitting diode (OLED) devices, but not limited thereto. In this embodiment, each electroluminescent device 20 is disposed on and substantially corresponding to each driving device 14, but not limited thereto. Each electroluminescent device 20 includes a first electrode 22, a light-emitting layer 24 and a second electrode 26. The first electrode 22 is disposed on a first passivation layer 17, and electrically connected to the corresponding driving device 14. The first passivation layer 17 is covered by a second passivation layer 18, and the second passivation layer 18 exposes the first electrode 22. The light-emitting layer 24 is disposed on the first electrode 22, and the second electrode 26 is disposed on the light-emitting layer 24. In this embodiment, the first electrode 22 is an anode, and the second electrode 26 is a cathode. The first electrode 22 is preferably a reflection electrode e.g. a metal electrode, so as to reflect light emitted by the light-emitting layer 24 for increasing light utilization, while the second electrode 26 is a transmission electrode, which allows light passing through. The light-emitting layer 24 may be, for example, an organic light-emitting layer, and the material of the light-emitting layer 24 may be selected from, for instance, red light-emitting material, green light-emitting material or blue light-emitting material based on the color of light to be

generated. The cover substrate **30** and the array substrate **12** are disposed oppositely, and bonded by a sealant **16**. The cover substrate **30** has a plurality of transmission regions **30T** and a reflection region **30R** disposed between the adjacent transmission regions **30T**. Each transmission region **30T** is substantially corresponding to each electroluminescent device **20**, while the reflection region **30R** is corresponding to the region between the adjacent electroluminescent devices **20**. For example, each transmission region **30T** of the cover substrate **30** is substantially corresponding to the light-emitting layer **24** of each electroluminescent device **20**, respectively.

[0016] In this embodiment, the cover substrate **30** includes a transparent base **31** and a patterned reflective film **32**. The transparent base **31** is base having transparent property such as glass base or plastic base, but not limited thereto. The transparent base **31** has an inner surface **31A** and an outer surface **31B**, where the inner surface **31A** is adjacent to and facing the array substrate **12**, while the outer surface **31B** is away from and opposite to the array substrate **12**. In this embodiment, the patterned reflective film **32** is disposed on the outer surface **31B** of the transparent base **31**. The patterned reflective film **32** has a plurality of openings **32A**, which allow light passing through and thus form the transmission regions **30T** of the cover substrate **30**. Each opening **32A** is substantially corresponding to each light-emitting layer **24**, and the size of the opening **32A** is preferably smaller than or equal to the size of the first electrode **22**. Specifically, since the transmission regions **30T** of the cover substrate **30** is implemented by the openings **32A** of the patterned reflective film **32**, each transmission region **30T** of the cover substrate **30** is substantially corresponding to each first electrode **22**, and the size of the transmission region **30T** is smaller than or equal to the size of the first electrode **22**. In this embodiment, the patterned reflective film **32** may be formed on the transparent base **31** by a deposition process. The deposition process may be a physical vapor deposition (PVD) process e.g. an evaporation process or a sputtering process, or a chemical vapor deposition (CVD) process, but not limited thereto. The patterned reflective film **32**, for example, may also be formed on the transparent base **31** by other deposition process such as coating, inkjet printing and bonding. In addition, the material of the patterned reflective film **32** may be various kinds of materials with high reflectivity, e.g. metal, but not limited thereto. The openings **32A** of the patterned reflective film **32** may be formed by a patterning process such as photolithography and etching process, but not limited thereto. For example, the patterned reflective film **32** with openings **32A** may be formed simultaneously by inkjet printing or bonding.

[0017] As shown in FIG. 1, the openings **32A** of the patterned reflective film **32** are corresponding to the light-emitting layers **24** respectively, and thus when displaying, the light **L1** emitted by the light-emitting layer **24** will all pass through the opening **32A** without loss. Consequently, the mirror electroluminescent display panel **10** may display images with high brightness and without color aberration. In another aspect, the ambient light **L2** is reflected by the patterned reflective film **32** to exhibit mirror effect. The transmission regions **30T** of the cover substrate **30** allow light passing through, while the reflection region **30R** allows light reflecting but does not allow light transmitting. In this embodiment, the transmission regions **30T** and the reflection region **30R** are formed by the transparent base **31** and the patterned reflective film **32**, but not limited thereto. For

example, the transmission regions **30T** and the reflection region **30R** may be formed by using a reflective material as the material of the cover substrate **30** and forming openings in the cover substrate **30**.

[0018] The mirror electroluminescent display panel is not limited by the aforementioned embodiment, and may have other different preferred embodiments. To simplify the description, the identical components in each of the following embodiments are marked with identical symbols. For making it easier to compare the difference between the embodiments, the following description will detail the dissimilarities among different embodiments and the identical features will not be redundantly described.

[0019] Please refer to FIG. 3. FIG. 3 is a cross-sectional view of a mirror electroluminescent display panel according to a second preferred embodiment of the present invention. As shown in FIG. 3, different from the first preferred embodiment, in this embodiment, the patterned reflective film **32** of the mirror electroluminescent display panel **50** is disposed on the inner surface **31A** of the transparent base **31**.

[0020] Please refer to FIG. 4. FIG. 4 is a cross-sectional view of a mirror electroluminescent display panel according to a third preferred embodiment of the present invention. As shown in FIG. 4, in this embodiment, the patterned reflective film **32** of the mirror electroluminescent display panel **60** is also disposed on the inner surface **31A** of the transparent base **31**. What is different from the second preferred embodiment is that the mirror electroluminescent display panel **60** further includes at least one touch sensing layer **62** disposed on the outer surface **31B** of the transparent base **31** for providing touch input function. The touch sensing layer **62** may be various types of touch sensing layer such as capacitive type touch sensing layer, resistive type touch sensing layer or optical type touch sensing layer. In addition, it is preferable that the touch sensing layer **62** does not overlap the opening **32A** of the patterned reflective film **32** to avoid adversely affecting display images of the mirror electroluminescent display panel **60**.

[0021] Please refer to FIG. 5. FIG. 5 is a cross-sectional view of a mirror electroluminescent display panel according to a fourth preferred embodiment of the present invention. As shown in FIG. 5, different from the first preferred embodiment, in this embodiment, the patterned reflective film **32** of the mirror electroluminescent display panel **70** is disposed inside the transparent base **31**, i.e. the patterned reflective film **32** is embedded in the transparent base **31**. In addition, a touch sensing layer (not shown) may be optionally disposed on the outer surface **31B** of the transparent base **31** for providing touch input function as disclosed in the third preferred embodiment.

[0022] In conclusion, the cover substrate of the mirror electroluminescent display panel of the present invention has the transmission regions corresponding to the light-emitting layers, and the transmission regions allow light emitted by the light-emitting layers passing through without loss. Consequently, the mirror electroluminescent display panel of the present invention can display images with high brightness and without color aberration. The reflection region of the cover substrate can reflect the ambient light to provide mirror effect.

[0023] Those skilled in the art will readily observe that numerous modifications and alterations of the device and method may be made while retaining the teachings of the

invention. Accordingly, the above disclosure should be construed as limited only by the metes and bounds of the appended claims.

What is claimed is:

1. A mirror electroluminescent display panel, comprising:
 - an array substrate;
 - a plurality of driving devices, disposed on the array substrate;
 - a plurality of electroluminescent devices, disposed on the array substrate, each of the electroluminescent devices comprising:
 - a first electrode, electrically connected to the corresponding driving device;
 - a light-emitting layer, disposed on the first electrode; and
 - a second electrode, disposed on the light-emitting layer;
 - a cover substrate, disposed opposite to the array substrate, the cover substrate having a plurality transmission regions, and a reflection region disposed between adjacent transmission regions, wherein each of the transmission regions is substantially corresponding to each of the light-emitting layers.
2. The mirror electroluminescent display panel of claim 1, wherein each of the transmission regions of the cover substrate is substantially corresponding to each of the first electrode.
3. The mirror electroluminescent display panel of claim 2, wherein a size of each of the transmission regions of the cover substrate is substantially smaller than or equal to that of the first electrode.
4. The mirror electroluminescent display panel of claim 1, wherein the cover substrate comprises a transparent base and a patterned reflective film, the patterned reflective film is substantially corresponding to the reflection region of the cover substrate, and the patterned reflective film has a plurality of openings substantially corresponding to each of the transmission regions of the cover substrate.

5. The mirror electroluminescent display panel of claim 4, wherein the patterned reflective film is formed on transparent base by a deposition process.

6. The mirror electroluminescent display panel of claim 4, wherein the transparent base has an inner surface and an outer surface, the inner surface faces the array substrate, and the outer surface is opposite to the array substrate.

7. The mirror electroluminescent display panel of claim 6, wherein the patterned reflective film is disposed on the outer surface of the transparent base.

8. The mirror electroluminescent display panel of claim 6, wherein the patterned reflective film is disposed on the inner surface of the transparent base.

9. The mirror electroluminescent display panel of claim 6, wherein the patterned reflective film is disposed inside the transparent base.

10. The mirror electroluminescent display panel of claim 6, further comprising at least one touch sensing layer disposed on the outer surface of the cover substrate.

11. The mirror electroluminescent display panel of claim 1, wherein the first electrode comprises a reflection electrode, and the second electrode comprises a transparent electrode.

12. A mirror electroluminescent display panel, comprising:

- an array substrate;

- a plurality of electroluminescent devices, disposed on the array substrate; and

- a cover substrate, disposed opposite to the array substrate, the cover substrate having a reflection region and a plurality of transmission regions, wherein each of the transmission regions is substantially corresponding to each of the electroluminescent devices, and the reflection region is substantially corresponding to a region between the adjacent electroluminescent devices.

* * * * *

专利名称(译)	镜面电致发光显示面板		
公开(公告)号	US20130049640A1	公开(公告)日	2013-02-28
申请号	US13/481960	申请日	2012-05-29
[标]申请(专利权)人(译)	KUO T YIN 协兴鸿		
申请(专利权)人(译)	郭慈尹 谢幸弘		
当前申请(专利权)人(译)	友达光电.		
[标]发明人	KUO TZU YIN HSIEH HSING HUNG		
发明人	KUO, TZU-YIN HSIEH, HSING-HUNG		
IPC分类号	H05B33/12		
CPC分类号	H01L51/524		
优先权	100130702 2011-08-26 TW		
其他公开文献	US9099676		
外部链接	Espacenet USPTO		

摘要(译)

一种镜面电致发光显示面板，包括阵列基板，多个驱动装置，多个电致发光装置和覆盖基板。驱动装置和电致发光装置设置在阵列基板上。每个电致发光器件包括电连接到相应驱动器件的第一电极，设置在第一电极上的发光层，和设置在发光层上的第二电极。覆盖基板和阵列基板相对设置。覆盖基板具有多个透射区域和设置在相邻透射区域之间的反射区域，并且每个透射区域分别对应于每个发光层。

